



Shire of Pingelly

Minutes

Ordinary Council Meeting
19 September 2018

Contents

1.	DECLARATION OF OPENING / ANNOUNCEMENT OF VISITORS	3
2.	ACKNOWLEDGEMENT OF COUNTRY	3
3.	ANNOUNCEMENTS BY THE PRESIDING MEMBER	3
3.1	Council Agenda Reports.....	3
4.	RECORD OF ATTENDANCE / APOLOGIES / APPROVED LEAVE OF ABSENCE	3
5.	RESPONSE TO PREVIOUS PUBLIC QUESTIONS TAKEN ON NOTICE.....	4
6.	PUBLIC QUESTION TIME	4
6.1	Ms A Murray	4
6.2	Mr C McLennan	5
7.	APPLICATIONS FOR LEAVE OF ABSENCE	6
8.	DISCLOSURES OF INTEREST	6
9.	CONFIRMATION OF MINUTES OF PREVIOUS MEETINGS.....	7
9.1	Ordinary Meeting – 15 August 2018	7
10.	PETITIONS / DEPUTATIONS / PRESENTATIONS / SUBMISSIONS	7
11.	REPORTS OF COMMITTEES OF COUNCIL.....	7
12.	REPORTS OF COUNCIL DELEGATES ON EXTERNAL COMMITTEES.....	8
13.	REPORTS FROM COUNCILLORS	9
16.1	Proposed Workers’ Accommodation – 34 Pitt Street, Pingelly	10
14	OFFICE OF THE CHIEF EXECUTIVE OFFICER	18
14.1	Public Question Time – Procedural Guidelines.....	18
14.2	Council Delegates to Committees.....	21
15.	DIRECTORATE OF CORPORATE AND COMMUNITY SERVICES.....	28
15.1	Monthly Statement of Financial Activity - July 2018	28
15.2	Monthly Statement of Financial Activity – August 2018.....	31
15.3	Accounts Paid by Authority – August 2018	34
16.	DIRECTORATE OF TECHNICAL SERVICES	36
16.2	Dual Fire Control Officer Appointment	37
16.3	Proposed Oversized Shed.....	39
16.4	Secondary Freight Route Project.....	48
16.5	Confidential Item – Land Use Lots 168 and 169 Taylor Street Pingelly.....	52
17.	ELECTED MEMBERS MOTIONS OF WHICH PREVIOUS NOTICE HAS BEEN GIVEN	53
17.1	Confidential Item – Presented Correspondence.....	53
18.	NEW BUSINESS OR URGENT BUSINESS INTRODUCED BY DECISION OF THE MEETING	53
19.	CLOSURE OF MEETING	53

1. DECLARATION OF OPENING / ANNOUNCEMENT OF VISITORS

The Chairman declared the meeting open at 2.02 pm.

2. ACKNOWLEDGEMENT OF COUNTRY

We acknowledge the Noongar people of this area and recognise their continuing connection to land, waters and community. We pay respect to both the Aboriginal and non-Aboriginal people past and present.

3. ANNOUNCEMENTS BY THE PRESIDING MEMBER

The Shire President advised he had received apologies from the Chief Executive Officer.

12509 Moved: Cr Hodges Seconded: Cr Hotham

Council Decision:

In lieu of the Chief Executive Officer's absence to elect Mr Barry Gibbs as Acting Chief Executive Officer for this Ordinary Council Meeting.

Carried 7:0

3.1 Council Agenda Reports

Please note that all elected members have been provided with the relevant information pertaining to each Officers reports within today's Agenda and the Officer Recommendations are based on Council Policy and or State Acts and Legislation.

4. RECORD OF ATTENDANCE / APOLOGIES / APPROVED LEAVE OF ABSENCE

At the Ordinary Council Meeting held on 18 July 2018 the following leave was granted:

12457 Moved: Cr Hodges Seconded: Cr Wood

Council Decision:

That Cr McBurney be granted leave from the 1st August to the 30th September 2018.

Carried 7:0

MEMBERS PRESENT

Cr WV Mulroney	President
Cr DI Freebairn	Deputy President
Cr BW Hotham	
Cr J McBurney	
Cr PJ Wood	
Cr JM Walton-Hassell	
Cr EJ Hodges	
Cr K Hastings	

STAFF IN ATTENDANCE

Mr S Billingham	Director Corporate Community Services
Mr B Gibbs	Director Technical Services
Mrs L Boddy	Executive Assistant

APOLOGIES

Mr G Pollock	Chief Executive Officer
--------------	-------------------------

OBSERVERS & VISITORS

Ms Ann Murray
Mrs Lee Steel
Mr Craig McLennan
Mrs Elly Bond

5. RESPONSE TO PREVIOUS PUBLIC QUESTIONS TAKEN ON NOTICE

As per correspondence dated 22 August 2018 to Mrs Lee Steel:

Summary of Question

So what is Council going to do with that if it is not correct?

Summary of Response

Taking the view that the letter was drafted with the best of intentions in mind, the general emphasis of the letter is correct and should not have been confusing to Pingelly Transport with its thorough knowledge of the road rules as they relate to RAV. It is possible however that Pingelly Transport assumed it may use Shaddick Street for its RAV vehicles. That would not be an accurate assumption, but it would be possible if it could successfully secure the necessary RAV or “last mile” permit to do so. My understanding is that such a permit for Shaddick Street has been sought, but refused by Main Roads WA (noting that these permits are not issued by local governments, meaning the Shire’s letter of 15 August 2018 carries no legal entitlement for the recipient). That being the case, any usage of Shaddick Street for RAV vehicles is therefore unauthorised and illegal, and any noticed use can be reported to Main Roads WA. It can then consider if it wishes to prosecute.

Summary of Question:

If Council did not approve this and sent them a letter saying they can run their business then I would like, when the CEO is available, for an apology as I was humiliated at the last meeting being told that the letter stated this business was not allowed whereas in fact it didn’t state that at all.

Summary of Response:

I have viewed the letter referred to at the Council Meeting (vis. Shire to Moultons of 15 September 2018) and accept that with the benefit of hindsight the letter could have been worded better and included more detail. As you will see in my letter to the Moultons, the word “Council” should ideally have been written as “Shire”. Whilst these two words are commonly used to describe a local government within the general public, in my view it is better as officers if we keep the terms separated, so that confusion is eliminated.

6. PUBLIC QUESTION TIME

Public question time opened at 2.04pm.

6.1 Ms A Murray

Summary of Question

What is happening with the relocation of Pingelly Transport? Where will they move to and when?

Summary of Response

The Acting Chief Executive Officer responded that currently the Shire is working with Pingelly Transport for a suitable location for the business to expand to. This would be the light industrial area and we are working in conjunction with them. The time take to do this is unknown at this point. The Shire is working towards getting the land released and a flora and fauna survey will be undertaken soon.

Summary of Question

It could be years before they move?

Summary of Response

To be realistic and go through all the requirements we need to go through it could be anywhere up to 18 months.

Summary of Question

You are not going to move them out in the mean time?

Summary of Response

We are trying to manage them where they are at the moment and in the end they will need to move.

6.2 Mr C McLennan

Summary of Question

Mr Shire President, will you be censoring public question time again this month?

Summary of Response

The Shire President responded yes I will.

Summary of Question

I note the CEO is absent - when was the last time the CEO attended an Ordinary Council Meeting?

Summary of Response

The Shire President responded he attended the July meeting.

Summary of Question

Out of Ordinary Council Meetings this year how many has the CEO attended?

Summary of Response

The Shire President responded February – July - he was here for all of them.

Summary of Question

How many Special Council Meetings has he attended this calendar year?

Summary of Response

The Shire President responded every Special Council Meeting we have had.

Summary of Question

With the PRACC estimate of probable costs - I have asked several times, can you give me an update as to where that is?

Summary of Response

The Shire President responded the last conversation I had with the CEO yesterday was they are working through it and has just about got it all together and it will be available for the October meeting. He is still endeavouring to find them all.

Summary of Question

I refer to the Special Council Meetings of 23 August 2017 and 8 August 2018 and minutes of both of those meetings items 8 and 11.1 – Item 11.1 Pingelly Bowling Club, Railway Station and Pingelly Football Club as examples. A considerable amount of money has been approved by this group and the Shire yet there are no disclosures of interest in deciding these monies. Is there a reason this hasn't happened?

Summary of Response

The Shire President responded the members of those committees have no financial gain from those organisations they are volunteers and it is up to the individual Councillor to put their disclosure of interest in - no one can make them.

Summary of Question

Wouldn't that be a good policy to take up to ensure they do put a disclosure of interest in?

Summary of Response

The Shire President responded that is in the Local Government Act.

Summary of Question

Surely it would be a good idea that council did, for example if I was getting \$5,000 for a club I was involved with and I made a decision on that surely that is a disclosure of interest?

Summary of Response

The Shire President responded I will take that on notice.

Summary of Question

With the Ordinary Council Meeting of 18 July and I know the CEO was here - in that meeting he casted dispersions on my character and personal abilities and also defamed me and made statements that he claimed were fact and were obviously wrong. None of this was ever raised while I was employed by and attending the Shire. As you are aware the QS figures were done and assessed and formed the documentation for the business case and the estimate of probably costs done in July.

He went on to claim I was part of that process. I was the Project Manager in charge of the project and in charge of document control for the early stages of the project. The business case and estimate of probable cost was dated July 2015 - how could I have been involved in that when I didn't start until August? I require a retraction of those statements defaming me and also particularly in terms of my professional ability.

Summary of Response

The Shire President responded I will take that on notice.

Summary of Question

Could you please reply as in the past refer to my lawyer and a copy to me.

Summary of Response

The Shire President responded We shall do.

As there were no more questions from the public, question time ended at 2.17pm.

7. APPLICATIONS FOR LEAVE OF ABSENCE

**12510 Moved Cr Freebairn Seconded: Cr Hastings
That Cr Hotham be granted leave from 10th October to 31st October 2018**

Carried 7:0

8. DISCLOSURES OF INTEREST

Nil.

9. CONFIRMATION OF MINUTES OF PREVIOUS MEETINGS

9.1 Ordinary Meeting – 15 August 2018

Statutory Environment:

Section 5.22 of the *Local Government Act* provides that minutes of all meetings are to be kept and submitted to the next ordinary meeting of the council or the committee, as the case requires, for confirmation.

Voting Requirements:

Simple Majority

12511 Moved: Cr Hodges Seconded: Cr Hotham

Recommendation and Council Decision:

That the Minutes of the Ordinary Meeting of the Council of the Shire of Pingelly held in the Council Chambers on 15 August 2018 be confirmed.

Carried 7:0

10. PETITIONS / DEPUTATIONS / PRESENTATIONS / SUBMISSIONS

Lee Steel presented a petition containing signatures of local ratepayers opposing the planning application for shearers' quarters in Pitt Street, Pingelly.

11. REPORTS OF COMMITTEES OF COUNCIL

Audit Committee	Full Council
Recreation & Cultural Committee	Member – Shire President Deputy – Deputy President
Bushfire Advisory Committee	Member – Cr Freebairn Deputy – Cr Hotham
Chief Executive Officer Performance Review Committee	Member – Shire President Member – Deputy President Member – Cr Hodges

12. REPORTS OF COUNCIL DELEGATES ON EXTERNAL COMMITTEES

Central Country Zone of WALGA	Delegate – Shire President Delegate – Deputy President Deputy – Cr Wood
Hotham-Dale Regional Road Sub-Group	Delegate – Shire President Deputy – Cr McBurney
Development Assessment Panel	Delegate – Cr Mulroney Delegate – Cr Freebairn Deputy – Cr Hodges Deputy – Cr Wood
Pingelly Tourism Group	Delegate – Cr McBurney Deputy – Cr Freebairn
Regional Waste Group	Delegate – Cr Mulroney Deputy – Cr Wood
Shires of Pingelly and Wandering Joint Local Emergency Management Committee	Delegate – Shire President Deputy – Cr Hodges
Aged Care Planning Regional Sub-Group (BBP)	Delegate – Shire President Delegate – Cr Hotham Deputy – Cr Freebairn
Youth Focus Group	Delegate – Cr Walton-Hassell Delegate – Cr Hastings Deputy – Cr McBurney
Pingelly Somerset Alliance	Delegate – Shire President Deputy – Cr McBurney

13. REPORTS FROM COUNCILLORS

Cr William Mulroney (President)

Meetings attended August:

10th Meeting with President and CEO
15th Meeting with A/CEO re August Council Meeting
15th Corporate Discussion and Council Meeting
16th PAAA Meeting with A/CEO re completion of Units
16th Meeting with A/CEO
23rd Meeting with Ratepayer in relation to relocation of a Business
27th PRACC Meeting
27th Pingelly Somerset Alliance bi-monthly meeting
28th Completion of PRACC with A/CEO and Architects
28th Inspection of PAAA with A/CEO and Architects
28th Radio interview with ABC regarding the opening of the PRACC
28th Board Meeting of PRACC
31st Opening of the PRACC

Meetings attended September:

5th Corporate Discussion
11th President and CEO Meeting
11th LEMC Meeting Pingelly
12th Agenda Briefing
19th Corporate Discussion and Council Meeting

Cr David Freebairn (Deputy President)

Nil

Cr Evan Hodges

Nil

Cr Bryan Hotham

Nil

Cr Jackie McBurney

Nil

Cr Kacey Hastings

Nil

Cr Michelle Walton-Hassell

Nil

Cr Peter Wood

Nil

Note: Standing Orders Apply

12512 Moved Cr Hastings Seconded Cr Walton-Hassell

Council Decision

That the order of business in the agenda be changed to allow Item 16.1 to be brought forward and dealt with at this time.

Carried 7:0

16.1 Proposed Workers' Accommodation – 34 Pitt Street, Pingelly

File Reference: A5430
Location: Lot 204 (34) Pitt Street, Pingelly
Applicant: R & T Cristinelli
Author: Planning Consultant
Date: 10 September 2018
Disclosure of Interest: Nil
Attachments: 1 – Site Plan
2 – Application
3 - Public Notice Advertisement
4 – Confidential Schedule of Submissions
(in separate Confidential Items attachment)
(Attachment 5 following purple sheet in separate attachments booklet)
Previous Reference: Nil

Summary:

A development application has been received by the Shire of Pingelly to install workers accommodation at Lot 204 (34) Pitt Street, Pingelly.

The property is zoned Mixed Use and the proposed workers' accommodation is a 'use not listed' in the zone.

Neighbouring property owners were invited to make submissions on the application and eight (8) submissions have been received objecting to the proposal. The issues raised in the objections have been considered in the assessment of the application.

The application is being recommended for refusal for the reasons outlined at the end of this Report.

Background:

Lot 204 (34) Pitt Street, Pingelly has an area of 1,821m² and currently contains a single dwelling. The property has access from both Pitt Street and Shaddick Street.

The development application proposes to install two transportable buildings containing four bedrooms with ensuites, which is eight (8) bedrooms in total. The rooms are proposed for used as workers' accommodation for shearing teams and will be located behind the existing dwelling that will be used for communal purposes. The buildings will be connected with a large outdoor timber deck. Six (6) parking spaces are proposed on site in conjunction with the development.

Comment:

The assessment of this application indicates that the proposed development is inconsistent with the provisions of the Scheme due to the intensity and location of the development proposed in a predominantly residential area that is likely to result in unacceptable impacts on the locality that cannot be reasonably managed by conditions and would result in an unacceptable level of compliance responsible and risk for the Shire.

Consultation:

Statutory

The application was notified in accordance with clause 64 of the *Planning and Development (Local Planning Schemes) Regulations 2015* (also known as the Deemed Provisions), including notification to neighbouring landowners.

Eight (8) submissions were received objecting to the proposal and zero (0) submissions received supporting the proposal. Refer to the Schedule of Submissions attached to this Report for details of the submissions.

Internal

The Shire's Environmental Health and Building Surveying Officer has been consulted during the assessment of this process who has raised concerns regarding the potential impacts, including noise emissions.

Statutory Environment:

Shire of Pingelly's Local Planning Scheme No.3 (LPS3)

The subject property is zoned Mixed Business under the provisions of LPS3 and the objectives of the zone are to:

- *“To provide for a range of commercial activities including showrooms and other forms of bulk retailing/display in strategically located areas.*
- *To ensure an orderly transition from and compatibility with existing residential uses.”*

The proposed development is best defined as “workforce accommodation” as defined in Schedule 1 of the *Planning and Development (Local Planning Schemes) Regulations 2015* (also known as the Model Provisions), which means:

- “premises, which may include modular or relocatable buildings, used —*
- (a) primarily for the accommodation of workers engaged in construction, resource, agricultural or other industries on a temporary basis; and*
 - (b) for any associated catering, sporting and recreation facilities for the occupants and authorised visitors.”*

“Workforce accommodation” is not listed in the Zoning Table, and accordingly, clause 4.4.2 of LPS3 states:

- “If a person proposes to carry out on land any use that is not specifically mentioned in the Zoning Table and cannot reasonably be determined as falling within the type, class or genus of activity of any other use category the local government may —*
- (a) determine that the use is consistent with the objectives of the particular zone and is therefore permitted;*
 - (b) determine that the use may be consistent with the objectives of the particular zone and thereafter follow the advertising procedures of clause 9.4 in considering an application for planning approval; or*
 - (c) determine that the use is not consistent with the objectives of the particular zone and is therefore not permitted.”*

To progress the application and to enable consultation, it is usual planning practice, if appropriate, to determine that the use may be consistent with the objectives of the zone, in the initial stages of the assessment of a development application. It is worth noting that adopting this stance does not affect the final outcome of the application, which shows that the proposal is considered to be inconsistent with the objectives of the zone.

The applicable clauses of the Scheme, including the ‘deemed provisions’ has been carried out as follows:

Section	Criteria	LPP / Scheme Provision	Proposed by Development	Criteria Met / Condition Required
4.4.2, LPS3	Use not listed	Permissibility to be determined if the use is, may be, or is not consistent with the zone objectives.	Workforce accommodation not listed in Zoning Table.	Zone objectives are to provide for a range of commercial activities; and to ensure an orderly transition from and compatibility with existing residential uses. Assessment indicates use may not be compatible.
5.1.1, LPS3	Compliance with development standards.	Development to comply with the Scheme.	Workers’ accommodation	Refer to assessment below.
Table 2	Development table – general	Boundary setbacks: 11m front; 7.5 rear; 5m side; 0.75 plot ratio; 1/15m ² parking; 15% landscaping.	Min.3.6m side; 7.4m rear; 0.16 plot ratio; 6 bays; landscaping not proposed.	Development complies, except rear variation of 0.1m; 13 parking bays required = 8 space shortfall. Refer to car parking and landscaping provisions.
5.5, LPS3	Variation to development standards	Local government may approve development despite non-compliances.	As above. Variations to rear setback; car parking bays; and landscaping.	Variation to rear setback considered acceptable. However, the variation to the car parking is not supported. Provision of landscaping can be conditioned.
5.10.1, LPS3	Amenity – relocated second-hand buildings	May permit if the building is in a satisfactory condition and design will not impact amenity; and complies with LPP.	Second-hand mine site type dongas. Refer to photographs.	The proposed buildings are not consistent with the surrounding single dwellings in the area. LPP requires painting and verandahs to improve appearance. However in this case, due to the intensity of the development proposed, will not alter appearance sufficiently to be consistent with the surrounding residential development.
5.11, LPS3	Landscaping	To be provided as per Table 2.	No details provided.	Landscaping will improve appearance of buildings. Can be conditioned.

Section	Criteria	LPP / Scheme Provision	Proposed by Development	Criteria Met / Condition Required
5.12, LPS3	Car Parking	Comply with Table 2.	6 spaces indicated on site plan.	A minimum of 13 car parking spaces are required. Variation is significant and is not supported.
5.13, LPS3	Traffic Management	May limit traffic entrances to one.	One entrance indicated on plans on Pitt Street.	Complies.
5.18.1, LPS3	Mixed use zone – comply with Table 2.	Refer above.	Refer above.	Variations proposed. Refer above.
5.18.3, LPS3	Mixed use zone – R-Codes.	Residential component to comply with R25.	Workers' accommodation proposed solely.	Not applicable. No new residential development is proposed.
5.18.4, LPS3	Mixed use zone – predominant established use	Not support commercial uses if predominant established use is residential unless the impacts can be buffered.	Commercial use proposed for temporary accommodation of shearers.	Predominant use in locality is residential with the exception of Pingelly Transport Depot, which is located approximately 90 metres north west of the site. Proposal does not comply.
67(a), Regs	Matters for consideration	The aims and provisions of this Scheme.	Workers' accommodation	Applicable aim of LPS3 is: "To provide the opportunities to improve the economic base for the Scheme Area through the mixing of compatible uses as recognised in the zoning and development tables." Proposal may not be compatible.
67(b), Regs	Matters for consideration	Requirements of orderly and proper planning; any proposed local planning scheme.	Workers' accommodation	Refer to assessment. Proper and orderly planning includes developments to be compatible with manageable impacts. Does not comply.
67(g), Regs	Matters for consideration	Provisions of any local planning policy. Relocated Second-Hand Dwellings.	Two second hand relocated buildings.	Refer to comments above for clause 5.10.1 of the Scheme.

Section	Criteria	LPP / Scheme Provision	Proposed by Development	Criteria Met / Condition Required
67(i), Regs	Matters for consideration	Any scheme review report.	Use not listed in Mixed Use zone.	Consolidated Scheme Report (2015). Not support commercial development unless impacts can be buffered. Does not comply.
67(m), Regs	Matters for consideration	Compatibility of the development.	Shearers' accommodation	Submitters all raise concerns regarding compatibility resulting from use, including noise and intensity of development. The intensity of the development is considered incompatible with the predominant residential use of the area.
67(n), Regs	Matters for consideration	Impacts on amenity of locality, including social impacts and character.	Shearers' accommodation	Significant potential for social impacts to arise affecting locality could result from proposal use. Buildings and intensity of use are considered out of character with existing residential dwellings. Proposal may not be consistent.
67(p), Regs	Matters for consideration	Adequate provision of landscaping.	No details provided.	Provision of landscaping can be conditioned.
67(q), Regs	Matters for consideration	Suitability of land, any risks, ie. Bushfire.	No details provided.	Property is identified on the DFES bushfire prone mapping. Bushfire report should have been submitted with application. If approved must be provided prior to commencement of any works.
67(s), Regs	Matters for consideration	Adequacy of access and manoeuvring of vehicles.	Existing access from Pitt Street. 6 parking spaces identified on site plan.	Refer to earlier comments. 6 spaces proposed are inadequate. Variation not supported. 13 spaces are required to satisfy scheme provisions. Does not comply.

Section	Criteria	LPP / Scheme Provision	Proposed by Development	Criteria Met / Condition Required
67(t), Regs	Matters for consideration	Traffic generation and impacts.	8 unrelated persons to occupy buildings.	Traffic generated will be higher than that expected from a medium density residential development, which could impact locality.
67(u), Regs	Matters for consideration	Availability and access to services, including disabled access and waste management.	No details provided.	Building codes will require disabled access. Sufficient space on site for waste storage.
67(v), Regs	Matters for consideration	Potential loss or benefit of community service.	Temporary shearers' accommodation.	Provision of appropriately located short term accommodation for visiting workers may be beneficial for the community.
67(x), Regs	Matters for consideration	Impact on the community as a whole not an individual.	Temporary shearers' accommodation.	Impacts on the locality are considered unacceptable as indicated in this Report.
67(y), Regs	Matters for consideration	Submissions received on the application.	Use not listed – workforce accommodation.	8 submissions received objecting to the proposal.
67(zb), Regs	Matters for consideration	Any other matter.	Existing dwelling is notated on the plans for kitchen, living, dining.	No information has been provided on number of occupants of dwelling; or whether a caretaker/ owner will be present.

Policy Implications:

The proposed development is inconsistent with the provisions of the Scheme. Approval may result in an undesirable precedent for incompatible developments in the Mixed Use zone. It is recommended that a Local Planning Policy be developed, as identified in the draft Consolidated Local Planning Scheme No. 3, to provide a better regulatory framework for the zone and to provide landowners and developers a clear policy position from the Shire.

Financial Implications:

If the Applicant appeals the determination to the State Administrative Tribunal, there may be financial implications for the Shire associated with that process.

Other financial implications for the Shire may be associated with increased staff resources relating to compliance, should the application be approved reliant on conditions to manage the development.

Strategic Implications:

Pingelly Local Planning Strategy 2004

A key Strategy for urban areas is to provide a variety of choice and lifestyles and housing is proposed within urban areas where it is economically, socially and environmentally viable. Quality in innovation and design of settlements should be encouraged so that landscape and streetscape character are maintained or enhanced.

The proposed installation of two second-hand mine-site style dongas for use as workers' accommodation will provide a variety of choice for temporary housing of shearers and other visiting workers. However, the quality and design may not be considered appropriate in an established predominantly residential area that may result in unacceptable social impacts in the locality.

Pingelly Local Planning Scheme No. 3 Consolidation Report

The Report states, in relation to the Mixed Use zone, that:

“Although the use of the mixed use areas which allows for a combination of residential and a business conducted from the same premises had not yet been utilised, it was agreed that it was important that the areas should be retained to ensure that a flexible option was available for those seeking to move to Pingelly and establish a business on the same lot as their residence.

It was considered desirable that a policy setting out development guidelines for these areas be prepared.”

This proposal does not propose to establish a business on the same site as a residence as intended by the Mixed Use zoning. It is proposed to convert the site entirely for uses associated with the short term accommodation.

As indicated in the Policy section of this Report, a policy is yet to be developed for the zone to guide development.

Risk Implications:

Risk	High
Risk Likelihood (based on history and with existing controls)	High
Risk Impact / Consequence	High
Risk Rating (Prior to Treatment or Control)	High
Principal Risk Theme	High
Risk Action Plan (Controls or Treatment Proposed)	Risks associated with this proposal cannot be managed through conditions or compliance. Refusal of the application has been recommended.

Risk Matrix

Consequence Likelihood		Insignificant	Minor	Moderate	Major	Catastrophic
		1	2	3	4	5
Almost Certain	5	Medium (5)	High (10)	High (15)	Extreme (20)	Extreme (25)
Likely	4	Low (4)	Medium (8)	High (12)	High (16)	Extreme (20)
Possible	3	Low (3)	Medium (6)	Medium (9)	High (12)	High (15)
Unlikely	2	Low (2)	Low (4)	Medium (6)	Medium (8)	High (10)
Rare	1	Low (1)	Low (2)	Low (3)	Low (4)	Medium (5)

A risk is often specified in terms of an event or circumstance and the consequences that may flow from it. An effect may be positive, negative or a deviation from the expected and may be related to the following objectives; occupational health and safety, financial, service interruption, compliance, reputation and environment. A risk matrix has been prepared and a risk rating of 1 has been determined for this item. Any items with a risk rating over 10 (considered to be high or extreme risk) will be added to the Risk Register, and any item with a risk rating over 17 will require a specific risk treatment plan to be developed.

Voting Requirements:

Simple Majority

12513 Moved: Cr Hodges Seconded: Cr Walton-Hassell

Recommendation and Council Decision:

1. That Council consider that the development application for workforce accommodation, a use not listed in the Pingelly Local Planning Scheme No. 3, is not consistent with the objectives of the Mixed Use zone and is therefore not permitted in accordance with clause 4.4.2(c).
2. That Council refuse the development application A5430 received on 30 July 2018 for workers' accommodation at Lot 204 (34) Pitt Street, Pingelly for the following reasons:
 - The proposal is inconsistent with the aims and provisions of the Pingelly Local Planning Scheme No. 3.
 - The proposal is inconsistent with the objectives of the Mixed Use zone in the Pingelly Local Planning Scheme No. 3.
 - The proposal does not comply with clause 5.18.1 of the Pingelly Local Planning Scheme No. 3.
 - The proposal does not comply with clause 5.18.4 of the Pingelly Local Planning Scheme No. 3.
 - The proposal is likely to result in unacceptable social impacts in the locality.

Carried 7:0

Lee Steel left the meeting at 2.30pm and did not return.

14 OFFICE OF THE CHIEF EXECUTIVE OFFICER

14.1 Public Question Time – Procedural Guidelines

File Reference: ADM0333
Location: Shire of Pingelly
Applicant: Director Corporate & Community Services
Author: Director Corporate & Community Services
Date: 10 September 2018
Disclosure of Interest: Nil
Attachments: Draft Shire of Pingelly Public Question Time - Guidelines
(Attachment 1 following blue sheet in separate attachments booklet)
Previous Reference: N/A

Summary:

Presented to Council for consideration of endorsement of the Draft Shire of Pingelly – Public Question Time Procedural Guidelines to assist in the management and conduct of Public Question at Council and Committee meetings.

Comment:

A draft Shire of Pingelly - Public Question Time - Procedural Guidelines has been prepared after consideration and discussion at the Corporate Discussion meeting held on 5 September 2018.

Consultation:

Acting Chief Executive Officer
Council

Statutory Environment:

The *Local Government Act 1995* states
s5.24 Question time for public

- (1) Time is to be allocated for questions to be raised by members of the public and responded to at —
 - (a) every ordinary meeting of a council; and
 - (b) such other meetings of councils or committees as may be prescribed.
- (2) Procedures and the minimum time to be allocated for the asking of and responding to questions raised by members of the public at council or committee meetings are to be in accordance with regulations.

The *Local Government (Administration) Regulations 1996* state:

Regulation 5 Question time for public, meetings that require prescribed (Act s. 5.24)

For the purposes of section 5.24(1)(b), the meetings at which time is to be allocated for questions to be raised by members of the public and responded to are —

- (a) every special meeting of a council;
- (b) every meeting of a committee to which the local government has delegated a power or duty.

Regulation 6. Question time for public, minimum time for (Act s. 5.24(2))

- (1) The minimum time to be allocated for the asking of and responding to questions raised by members of the public at ordinary meetings of councils and meetings referred to in regulation 5 is 15 minutes.
- (2) Once all the questions raised by members of the public have been asked and responded to at a meeting referred to in subregulation (1), nothing in these regulations prevents the unused part of the minimum question time period from being used for other matters.

Regulation 7. Question time for public, procedure for (Act s. 5.24(2))

- (1) Procedures for the asking of and responding to questions raised by members of the public at a meeting referred to in regulation 6(1) are to be determined —
 - (a) by the person presiding at the meeting; or
 - (b) in the case where the majority of members of the council or committee present at the meeting disagree with the person presiding, by the majority of those members, having regard to the requirements of subregulations (2), (3) and (5).
- (2) The time allocated to the asking of and responding to questions raised by members of the public at a meeting referred to in regulation 6(1) is to precede the discussion of any matter that requires a decision to be made by the council or the committee, as the case may be.
- (3) Each member of the public who wishes to ask a question at a meeting referred to in regulation 6(1) is to be given an equal and fair opportunity to ask the question and receive a response.
- (4) Nothing in subregulation (3) requires —
 - (a) a council to answer a question that does not relate to a matter affecting the local government; or
 - (b) a council at a special meeting to answer a question that does not relate to the purpose of the meeting; or
 - (c) a committee to answer a question that does not relate to a function of the committee.
- (5) If, during the time allocated for questions to be raised by members of the public and responded to, a question relating to a matter in which a relevant person has an interest, as referred to in section 5.60, is directed to the relevant person, the relevant person is to —
 - (a) declare that he or she has an interest in the matter; and
 - (b) allow another person to respond to the question.

Guidance on Public Question Time is also provided by the Department of Local Government, Sport and Cultural Industries in Local Government Operational Guidelines number 3 Managing Public Question Time.

Policy Implications:

There are no direct policy implications arising from this amendment, however this procedural guidelines if adopted by Council it would set out the process and procedure for the operation of Public Question Time at all Public Council and Committee meetings.

Financial Implications:

There are no known financial implications upon either the Council's current budget or long term financial plan.

Strategic Implications:

There are no known significant strategic implications relating to this report.

Voting Requirements:

Simple Majority.

12514 Moved: Cr Wood Seconded: Cr Hotham

Recommendation and Council Decision:

That Council adopts and implements the Shire of Pingelly Public Question Time - Procedural Guidelines as presented, commencing 1 October 2018.

Carried 7:0

14.2 Council Delegates to Committees

File Reference: ADM0000
Location: Shire of Pingelly
Applicant: Shire of Pingelly
Author: Chief Executive Officer
Date: 9 September 2018
Disclosure of Interest: Nil
Attachments: Nil
Previous Reference: Ordinary Meeting held on 18 July 2018 item 14.3

Summary:

Council to consider reviewing and appointing members, delegates and deputies to Committees (internal and external).

Background:

Council has the following Committees:

- Audit Committee Full Council
Charter:
To:
 - assist the auditor and ensure that audits are conducted successfully and timely;
 - meet with the auditor at least once a year;
 - examine the auditor's report and ensure appropriate action is taken; and
 - report on actions taken in respect of any issues raised by the auditor to council.
- Recreation and Cultural Committee
Charter:
 - To provide recommendations to the Shire of Pingelly on sport and recreation matters
- Bushfire Advisory Committee
Charter:
To advise Council on all matters relating to:
 - the prevention, controlling and extinguishing of bush fires;
 - prosecutions for breaches of the Bush Fire Act;
 - the formation and de-formation of bush fire brigades;
 - the co-ordination of the efforts and activities of the bush fire brigades; and
 - any other matter relating to bush fire control
- Medical and Aged Care Services Committee
Charter: To investigate health issues relevant to Pingelly
- Chief Executive Officer Performance Review Committee
- **Charter:** To complete the Annual Performance Review of the Chief Executive Officer

Current committees and their members/delegates are detailed below:

- Audit Committee Full Council
- Recreation & Cultural Committee Member – Shire President
Member – Deputy President
- Bushfire Advisory Committee Member – Cr Freebairn
Deputy – Cr Hotham
- Chief Executive Officer Performance Review Committee Member – Shire President
Member – Deputy President
Member – Cr Hodges

Council has previously appointed delegates to the following external committees:

- Central Country Zone of WALGA Delegate – Shire President
Delegate – Deputy President
Deputy – Cr Wood
- Hotham-Dale Regional Road Sub-Group Delegate – Shire President
Deputy – Cr McBurney
- Development Assessment Panel Delegate – Cr Mulroney
Delegate – Cr Freebairn

Deputy – Cr Hodges
Deputy – Cr Wood
- Pingelly Tourism Group Delegate – Cr McBurney
Deputy – Cr Freebairn
- Regional Waste Group Delegate – Shire President
Deputy – Cr Wood
- Shires of Pingelly and Wandering Joint Local Emergency Management Committee Delegate – Shire President
Deputy – Cr Hodges
- Aged Care Planning Regional Sub-Group (BBP) Delegate – Shire President
Delegate – Cr Hotham
Deputy – Cr Freebairn
- Youth Focus Group Delegate – Cr Walton-Hassell
Delegate – Cr Hastings
Deputy – Cr McBurney
- Pingelly Somerset Alliance Delegate – Shire President
Deputy – Cr McBurney

Comment:

At the Corporate Discussion meeting held on 15 August 2018 Council requested to the Acting Chief Executive Officer that an agenda item be prepared to appoint Council delegates to the Pingelly Early Years Network and the Pingelly Wellbeing Group.

Consultation:

Acting Chief Executive Officer and Councillors.

Statutory Environment:

Section 5.8 of the *Local Government Act* (Establishment of committees) provides that a local government may establish* committees of three or more persons to assist the council and to exercise the powers and discharge the duties of the local government that can be delegated to committees.

- *Absolute majority required.

Section 5.9 (Types of committees) provides that:

- (1) In this section **other person** means a person who is not a council member or an employee.
- (2) A committee is to comprise —
 - (a) council members only;
 - (b) council members and employees;
 - (c) council members, employees and other persons;
 - (d) council members and other persons;
 - (e) employees and other persons; or
 - (f) other persons only.

Section 5.10 (Appointment of committee members) provides that:

- (1) A committee is to have as its members —
 - (a) persons appointed* by the local government to be members of the committee (other than those referred to in paragraph (b)); and
 - (b) persons who are appointed to be members of the committee under subsection (4) or (5).
 - *Absolute majority required.
- (2) At any given time each council member is entitled to be a member of at least one committee referred to in section 5.9(2)(a) or (b) and if a council member nominates himself or herself to be a member of such a committee or committees, the local government is to include that council member in the persons appointed under subsection (1)(a) to at least one of those committees as the local government decides.
- (3) Section 52 of the *Interpretation Act 1984* applies to appointments of committee members other than those appointed under subsection (4) or (5) but any power exercised under section 52(1) of that Act can only be exercised on the decision of an absolute majority of the local government.
- (4) If at a meeting of the council a local government is to make an appointment to a committee that has or could have a council member as a member and the mayor or president informs the local government of his or her wish to be a member of the committee, the local government is to appoint the mayor or president to be a member of the committee.
- (5) If at a meeting of the council a local government is to make an appointment to a committee that has or will have an employee as a member and the CEO informs the local government of his or her wish —
 - (a) to be a member of the committee; or
 - (b) that a representative of the CEO be a member of the committee,the local government is to appoint the CEO or the CEO's representative, as the case may be, to be a member of the committee.

Section 5.11A (Deputy committee members) provides:

- (1) The local government may appoint a person to be a deputy of a member of a committee and may terminate such an appointment* at any time.
 - **Absolute majority required.*
- (2) A person who is appointed as a deputy of a member of a committee is to be —
 - (a) if the member of the committee is a council member — a council member; or
 - (b) if the member of the committee is an employee — an employee; or
 - (c) if the member of the committee is not a council member or an employee — a person who is not a council member or an employee; or
 - (d) if the member of the committee is a person appointed under section 5.10(5) — a person nominated by the CEO.
- (3) A deputy of a member of a committee may perform the functions of the member when the member is unable to do so by reason of illness, absence or other cause.
- (4) A deputy of a member of a committee, while acting as a member, has all the functions of and all the protection given to a member.

Section 5.11 (Tenure of committee membership)

- (1) Where a person is appointed as a member of a committee under section 5.10(4) or (5), the person's membership of the committee continues until —
 - (a) the person no longer holds the office by virtue of which the person became a member, or is no longer the CEO, or the CEO's representative, as the case may be;
 - (b) the person resigns from membership of the committee;
 - (c) the committee is disbanded; or
 - (d) the next ordinary elections day, whichever happens first.
- (2) Where a person is appointed as a member of a committee other than under section 5.10(4) or (5), the person's membership of the committee continues until —
 - (a) the term of the person's appointment as a committee member expires;
 - (b) the local government removes the person from the office of committee member or the office of committee member otherwise becomes vacant;
 - (c) the committee is disbanded; or
 - (d) the next ordinary elections day, whichever happens first.

Section 5.12 (Election of presiding members and deputies)

- (1) The members of a committee are to elect a presiding member from amongst themselves in accordance with Schedule 2.3, Division 1 as if the references in that Schedule —
 - (a) to "office" were references to "office of presiding member";
 - (b) to "council" were references to "committee"; and
 - (c) to "councillors" were references to "committee members".
- (2) The members of a committee may elect a deputy presiding member from amongst themselves but any such election is to be in accordance with Schedule 2.3, Division 2 as if the references in that Schedule —
 - (a) to "office" were references to "office of deputy presiding member";
 - (b) to "council" were references to "committee";
 - (c) to "councillors" were references to "committee members"; and
 - (d) to "mayor or president" were references to "presiding member".

Section 5.15 (Reduction of quorum) provides that the local government may reduce* the number of offices of committee member required for a quorum at a committee meeting specified by the local government if there would not otherwise be a quorum for the meeting.

- **Absolute majority required.*

Section 5.16 (Delegation of some powers and duties to certain committees) provides that:

- (1) Under and subject to section 5.17, a local government may delegate* to a committee any of its powers and duties other than this power of delegation.
 - **Absolute majority required.*
- (2) A delegation under this section is to be in writing and may be general or as otherwise provided in the instrument of delegation.
- (3) Without limiting the application of sections 58 and 59 of the Interpretation Act 1984 —
 - (a) a delegation made under this section has effect for the period of time specified in the delegation or if no period has been specified, indefinitely; and
 - (b) any decision to amend or revoke a delegation under this section is to be by an absolute majority.
- (4) Nothing in this section is to be read as preventing a local government from performing any of its functions by acting through another person.

Section 5.17 (Limits on delegation of powers and duties to certain committees)

- (1) A local government can delegate —
 - (a) to a committee comprising council members only, any of the council's powers or duties under this Act except —
 - (i) any power or duty that requires a decision of an absolute majority or a 75% majority of the local government; and
 - (ii) any other power or duty that is prescribed;
 - (b) to a committee comprising council members and employees, any of the local government's powers or duties that can be delegated to the CEO under Division 4; and
 - (c) to a committee referred to in section 5.9(2)(c), (d) or (e), any of the local government's powers or duties that are necessary or convenient for the proper management of —
 - (i) the local government's property; or
 - (ii) an event in which the local government is involved.
- (2) A local government cannot delegate any of its powers or duties to a committee referred to in section 5.9(2)(f).

Section 5.19 (Quorum for meetings) provides that the quorum for a meeting of a council or committee is at least 50% of the number of offices (whether vacant or not) of member of the council or the committee.

Section 7.1A (Audit committee) provides that:

- (1) A local government is to establish an audit committee of 3 or more persons to exercise the powers and discharge the duties conferred on it.
- (2) The members of the audit committee of a local government are to be appointed * by the local government and at least 3 of the members, and the majority of the members are to be council members.
 - **Absolute majority required.*
- (3) A CEO is not to be a member of an audit committee and may not nominate a person to be a member of an audit committee or have a person to represent him or her as a member of an audit committee.
- (4) An employee is not to be a member of an audit committee.

Section 67 of the *Bush Fires Act* provides that:

- (1) A local government may at any time appoint such persons as it thinks fit as a bush fire advisory committee for the purpose of advising the local government regarding all matters relating to the preventing, controlling and extinguishing of bush fires, the planning of the layout of fire-breaks in the district, prosecutions for breaches of this Act, the formation of bush fire brigades and the grouping thereof under group brigade officers, the ensuring of co-operation and co-ordination of bush fire brigades in their efforts and activities, and any other matter relating to bush fire control whether of the same kind, as, or a different kind from, those specified in this subsection.

- (2) A committee appointed under this section shall include a member of the council of the local government nominated by it for that purpose as a member of the committee, and the committee shall elect one of their number to be chairman thereof.
- (3) In respect to a committee so appointed, the local government shall fix the quorum for the transaction of business at meetings of the committee and may —
 - (a) make rules for the guidance of the committee;
 - (b) accept the resignation in writing of, or remove, any member of the committee; and
 - (c) where for any reason a vacancy occurs in the office of a member of the committee, appoint a person to fill that vacancy.
- (4) A committee appointed under this section —
 - (a) may from time to time meet and adjourn as the committee thinks fit;
 - (b) shall not transact business at a meeting unless the quorum fixed by the local government is present;
 - (c) is answerable to the local government and shall, as and when required by the local government, report fully on its activities.

Section 5.8 of the *Local Government Act 1995* and section 38 of the *Emergency Management Act 2005*, establishes the Shires of Pingelly and Wandering Joint Local Emergency Management Committee;

1. In accordance with provisions of Section 5.9 of the *Local Government Act 1995* resolves that the Local Emergency Management Committees are to comprise of Councillors, Staff and Other Persons;

Policy Implications:

Nil

Financial Implications:

Nil

Strategic Implications:

N/A

Risk Implications:

Risk	Low (1)
Risk Likelihood (based on history and with existing controls)	Low (1)
Risk Impact / Consequence	Low (1)
Risk Rating (Prior to Treatment or Control)	Low (1)
Principal Risk Theme	Low (1)
Risk Action Plan (Controls or Treatment Proposed)	Low (1)

Risk Matrix

Consequence Likelihood		Insignificant	Minor	Moderate	Major	Catastrophic
		1	2	3	4	5
Almost Certain	5	Medium (5)	High (10)	High (15)	Extreme (20)	Extreme (25)
Likely	4	Low (4)	Medium (8)	High (12)	High (16)	Extreme (20)
Possible	3	Low (3)	Medium (6)	Medium (9)	High (12)	High (15)
Unlikely	2	Low (2)	Low (4)	Medium (6)	Medium (8)	High (10)
Rare	1	Low (1)	Low (2)	Low (3)	Low (4)	Medium (5)

A risk is often specified in terms of an event or circumstance and the consequences that may flow from it. An effect may be positive, negative or a deviation from the expected and may be related to the following objectives; occupational health and safety, financial, service interruption, compliance, reputation and environment. A risk matrix has been prepared and a risk rating of 1 has been determined for this item.

Any items with a risk rating over 10 (considered to be high or extreme risk) will be added to the Risk Register, and any item with a risk rating over 17 will require a specific risk treatment plan to be developed.

Voting Requirements:

Absolute Majority

12515 Moved: Cr Freebairn Seconded: Cr Hotham

Recommendation and Council Decision 1:

That Council discuss appointing Council Delegates to the following External Committees:

- | | |
|---|-------------------------------------|
| • Pingelly Early Years Network | Delegate – Cr Hastings |
| • Pingelly Community Wellbeing Group | Delegate – Cr Walton-Hassell |

Carried 7:0

12516 Moved: Cr Freebairn Seconded: Cr Hotham

Recommendation and Council Decision 2:

That Council endorse the following Elected Members of Council to be the Council Delegates to External Committees.

- | | |
|---|-------------------------------------|
| • Pingelly Early Years Network | Delegate – Cr Hastings |
| • Pingelly Community Wellbeing Group | Delegate – Cr Walton-Hassell |

Carried 7:0

15. DIRECTORATE OF CORPORATE AND COMMUNITY SERVICES

15.1 Monthly Statement of Financial Activity - July 2018

File Reference: ADM0075
Location: N/A
Applicant: Director Corporate & Community Services
Author: Director Corporate & Community Services
Date: 21 August 2018
Disclosure of Interest: Nil
Attachments: Monthly Statements of Financial Activity for the period 1 July 2018 to 31 July 2018
(Attachment 2 following green sheet in separate attachments booklet)
Previous Reference: N/A

Summary:

In Accordance with the *Local Government Act 1995* Section 5.25 (1) and *Local Government (Financial Management) Regulations 1996*, Monthly Financial Statements are required to be presented to Council, in order to ensure that income and expenditure is in keeping with budget forecasts.

The Monthly Statements of Financial Activity for the month of July 2018 is attached for Council consideration and adoption.

Background:

In order to prepare the monthly statements, the following reconciliations have been completed and verified:

- Reconciliation of assets, payroll and taxation services;
- Reconciliation of all shire's bank accounts, including term deposits;
- Reconciliation of Rates, including outstanding debtors;
- Reconciliation of Sundry Creditors and Debtors;

Consultation:

Chief Executive Officer.

Statutory Environment:

Local Government Act 1995;

Local Government (Financial Management) Regulations 1996

Section 34: Financial Reports to be Prepared

(1) A local government is to prepare each month a statement of financial activity reporting on the sources and applications of funds, as set out in the annual budget under regulation 22(1)(d), for that month in the following detail -

- (a) Annual budget estimates, taking into account any expenditure incurred for an additional purpose under section 6.8(1) (b) or (c);
- (b) Budget estimates to the end of the month to which the statement relates;
- (c) Actual amounts of expenditure, revenue and income to the end of the month to which the statement relates;
- (d) Material variances between the comparable amounts referred to in paragraphs (b) and (c); and
- (e) The net current assets at the end of the month to which the statement relates.

- (2) Each statement of financial activity is to be accompanied by documents containing -
- (a) An explanation of the composition of the net current assets of the month to which the statement relates, less committed assets and restricted assets;
 - (b) An explanation of each of the material variances referred to in sub regulation (1) (d); and
 - (c) Such other supporting information as is considered relevant by the local government.
- (3) The information in a statement of financial activity may be shown -
- (a) According to nature and type classification;
 - (b) By program; or
 - (c) By business unit.
- (4) A statement of financial activity, and the accompanying documents referred to in sub regulation (2), is to be -
- (a) Presented to the council -
 - (i) At the next ordinary meeting of the council following the end of the month to which the statement relates; or
 - (ii) if the statement is not prepared in time to present it to the meeting referred to in subparagraph (i), to the next ordinary meeting of the council after that meeting; and
 - (b) Recorded in the minutes of the meeting at which it is presented.
- (5) Each financial year, a local government is to adopt a percentage or value, calculated in accordance with AAS 5, to be used in statements of financial activity for reporting material variances.

Policy Implications:

There are no policy implications.

Financial Implications:

There are no significant trends or issues to be reported. The report and officer recommendation is consistent with Council's adopted Budget 2018/2019.

Strategic Implications:

There are no known significant strategic implications.

Risk Implications:

Risk	Low (2)
Risk Likelihood (based on history and with existing controls)	Low (2)
Risk Impact / Consequence	Low (2)
Risk Rating (Prior to Treatment or Control)	Low (2)
Principal Risk Theme	Low (2)
Risk Action Plan (Controls or Treatment Proposed)	Low (2)

Risk Matrix

Consequence Likelihood		Insignificant 1	Minor 2	Moderate 3	Major 4	Catastrophic 5
Almost Certain	5	Medium (5)	High (10)	High (15)	Extreme (20)	Extreme (25)
Likely	4	Low (4)	Medium (8)	High (12)	High (16)	Extreme (20)
Possible	3	Low (3)	Medium (6)	Medium (9)	High (12)	High (15)
Unlikely	2	Low (2)	Low (4)	Medium (6)	Medium (8)	High (10)
Rare	1	Low (1)	Low (2)	Low (3)	Low (4)	Medium (5)

A risk is often specified in terms of an event or circumstance and the consequences that may flow from it. An effect may be positive, negative or a deviation from the expected and may be related to the following objectives; occupational health and safety, financial, service interruption, compliance, reputation and environment. A risk matrix has been prepared and a risk rating of 1 has been determined for this item. Any items with a risk rating over 10 (considered to be high or extreme risk) will be added to the Risk Register, and any item with a risk rating over 17 will require a specific risk treatment plan to be developed.

Voting Requirements:

Simple Majority.

12517 Moved: Cr Hodges Secoded: Cr Wood

Recommendation and Council Decision:

That with respect to the Monthly Statements of Financial Activity for the month ending 31 July 2018 be accepted and material variances be noted.

Carried 7:0

15.2 Monthly Statement of Financial Activity – August 2018

File Reference:	ADM0075
Location:	N/A
Applicant:	Director Corporate & Community Services
Author:	Director Corporate & Community Services
Date:	11 September 2018
Disclosure of Interest:	Nil
Attachments:	Monthly Statements of Financial Activity for the period 1 July 2018 to 31 August 2018 (Attachment 3 following orange sheet in separate attachments booklet)
Previous Reference:	N/A

Summary:

In Accordance with the *Local Government Act 1995* Section 5.25 (1) and *Local Government (Financial Management) Regulations 1996*, Monthly Financial Statements are required to be presented to Council, in order to ensure that income and expenditure is in keeping with budget forecasts.

The Monthly Statements of Financial Activity for the month of August 2018 is attached for Council consideration and adoption.

Background:

In order to prepare the monthly statements, the following reconciliations have been completed and verified:

- Reconciliation of assets, payroll and taxation services;
- Reconciliation of all shire's bank accounts, including term deposits;
- Reconciliation of Rates, including outstanding debtors;
- Reconciliation of Sundry Creditors and Debtors;

Consultation:

Chief Executive Officer.

Statutory Environment:

Local Government Act 1995;

Local Government (Financial Management) Regulations 1996

Section 34: Financial Reports to be Prepared

(1) A local government is to prepare each month a statement of financial activity reporting on the sources and applications of funds, as set out in the annual budget under regulation 22(1)(d), for that month in the following detail -

- (a) Annual budget estimates, taking into account any expenditure incurred for an additional purpose under section 6.8(1) (b) or (c);
- (b) Budget estimates to the end of the month to which the statement relates;
- (c) Actual amounts of expenditure, revenue and income to the end of the month to which the statement relates;
- (d) Material variances between the comparable amounts referred to in paragraphs (b) and (c); and
- (e) The net current assets at the end of the month to which the statement relates.

- (2) Each statement of financial activity is to be accompanied by documents containing -
- (a) An explanation of the composition of the net current assets of the month to which the statement relates, less committed assets and restricted assets;
 - (b) An explanation of each of the material variances referred to in sub regulation (1) (d); and
 - (c) Such other supporting information as is considered relevant by the local government.
- (3) The information in a statement of financial activity may be shown -
- (a) According to nature and type classification;
 - (b) By program; or
 - (c) By business unit.
- (4) A statement of financial activity, and the accompanying documents referred to in sub regulation (2), is to be -
- (a) Presented to the council -
 - (i) At the next ordinary meeting of the council following the end of the month to which the statement relates; or
 - (ii) if the statement is not prepared in time to present it to the meeting referred to in subparagraph (i), to the next ordinary meeting of the council after that meeting; and
 - (b) Recorded in the minutes of the meeting at which it is presented.
- (5) Each financial year, a local government is to adopt a percentage or value, calculated in accordance with AAS 5, to be used in statements of financial activity for reporting material variances.

Policy Implications:

There are no policy implications.

Financial Implications:

There are no significant trends or issues to be reported. The report and officer recommendation is consistent with Council's adopted Budget 2018/2019.

Strategic Implications:

There are no known significant strategic implications.

Risk Implications:

Risk	Low (2)
Risk Likelihood (based on history and with existing controls)	Low (2)
Risk Impact / Consequence	Low (2)
Risk Rating (Prior to Treatment or Control)	Low (2)
Principal Risk Theme	Low (2)
Risk Action Plan (Controls or Treatment Proposed)	Low (2)

Risk Matrix

Consequence Likelihood		Insignificant 1	Minor 2	Moderate 3	Major 4	Catastrophic 5
Almost Certain	5	Medium (5)	High (10)	High (15)	Extreme (20)	Extreme (25)
Likely	4	Low (4)	Medium (8)	High (12)	High (16)	Extreme (20)
Possible	3	Low (3)	Medium (6)	Medium (9)	High (12)	High (15)
Unlikely	2	Low (2)	Low (4)	Medium (6)	Medium (8)	High (10)
Rare	1	Low (1)	Low (2)	Low (3)	Low (4)	Medium (5)

A risk is often specified in terms of an event or circumstance and the consequences that may flow from it. An effect may be positive, negative or a deviation from the expected and may be related to the following objectives; occupational health and safety, financial, service interruption, compliance, reputation and environment. A risk matrix has been prepared and a risk rating of 1 has been determined for this item. Any items with a risk rating over 10 (considered to be high or extreme risk) will be added to the Risk Register, and any item with a risk rating over 17 will require a specific risk treatment plan to be developed.

Voting Requirements:

Simple Majority.

12518 Moved: Cr Hodges Secoded: Cr Hotham

Recommendation and Council Decision:

That with respect to the Monthly Statements of Financial Activity for the month ending 31 August 2018 be accepted and material variances be noted.

Carried 7:0

15.3 Accounts Paid by Authority – August 2018

File Reference: ADM0066
Location: Shire of Pingelly
Applicant: Director Corporate & Community Services
Author: Senior Finance Officer
Date: 21 August 2018
Disclosure of Interest: Nil
Attachments: List of Accounts
(Attachment 4 following red sheet in separate attachments booklet)
Previous Reference: N/A

Summary:

Council endorsement is required for accounts made by authority for the month of August 2018.

Comment:

Unless otherwise identified, all payments have been made in accordance with Council's 2018/19 Budget.

Consultation:

Nil

Statutory Environment:

Regulation 12 of the *Local Government (Financial Management) Regulations* provides that:

- (1) A payment may only be made from the municipal fund or the trust fund —
 - (a) if the local government has delegated to the CEO the exercise of its power to make payments from those funds — by the CEO; or
 - (b) otherwise, if the payment is authorised in advance by a resolution of the council.
- (2) The council must not authorise a payment from those funds until a list prepared under regulation 13(2) containing details of the accounts to be paid has been presented to the council.

Regulation 13 of the *Local Government (Financial Management) Regulations* provides that:

- (1) If the local government has delegated to the CEO the exercise of its power to make payments from the municipal fund or the trust fund, a list of accounts paid by the CEO is to be prepared each month showing for each account paid since the last such list was prepared —
 - (a) the payee's name;
 - (b) the amount of the payment;
 - (c) the date of the payment; and
 - (d) sufficient information to identify the transaction.
- (2) A list of accounts for approval to be paid is to be prepared each month showing —
 - (a) for each account which requires council authorisation in that month —
 - (i) the payee's name;
 - (ii) the amount of the payment; and
 - (iii) sufficient information to identify the transaction; and
 - (b) the date of the meeting of the Council to which the list is to be presented.
- (3) A list prepared under sub regulation (1) or (2) is to be —
 - (a) presented to the Council at the next ordinary meeting of the council after the list is prepared; and
 - (b) recorded in the minutes of that meeting.

Policy Implications:

There are no policy implications arising from this amendment.

Financial Implications:

There are no known financial implications upon either the Council’s current budget or long term financial plan.

Strategic Implications:

There are no known significant strategic implications relating to the report.

Voting Requirements:

Simple Majority.

12519 Moved: Cr Hastings Seconded: Cr Hodges

Recommendation and Council Decision:

That Council endorse:

- 1. the Accounts for Payments for August 2018 as presented:**

August 2018	
MUNI - 117984856	
EFT 5173 – 5278	\$765,390.62
CHEQUE 24579 – 24589	\$50,051.58
TRUST ACCOUNTS	
DEPT OF TRANSPORT – DD9956.1 – DD10020.1	\$42,452.70
TRUST FUND – 1932-1933	\$180.00
DIRECT DEBIT -	
DD9954.1 – DD9980.9 & EFT 5190 - 5232 – Pay and Super	\$21,372.66
CREDIT CARD	
DD99782.1	\$5,554.19
GRAND TOTAL	\$885,001.75

Notification	Explanation
Nil	

- 2. that the Chief Executive Officer and Acting Chief Executive Officer are authorised to approve variations for the Pingelly Recreation and Cultural Centre (PRACC) and Pingelly Age Appropriate Accommodation (PAAA) tender projects (within budget limitations) and note the following variations were approved during the above period:**

Variation #54 – Authorised by Acting Chief Executive Officer – Decking - \$46,290 excl gst.

Carried 7:0

16. DIRECTORATE OF TECHNICAL SERVICES

16.1 Proposed Workers' Accommodation – 34 Pitt Street, Pingelly

This item was brought forward as per Council Resolution 12512.

16.2 Dual Fire Control Officer Appointment

File Reference: ADM0313
Location: Shire of Wickepin
Applicant: Shire of Wickepin
Author: Administration Officer Technical
Date: 23 August 2018
Disclosure of Interest: Nil
Attachments: Nil

Summary:

Council to consider the appointment of dual fire control officers with the Shire of Wickepin for the 2018/19 season.

Background:

The Shire of Wickepin has requested the appointment of:

- Roger Butler
- Colin Coxon
- Steve Rose

as a dual fire control officers for the 2018/19 fire season.

Comment:

The Shire of Wickepin has requested the appointment of the above fire control officers to Dual Fire Control Officers for the Shire of Wickepin and the Shire of Pingelly.

Once approval has been given the appointment of the Dual Fire Control Officers will need to be advertised locally, through a local newspaper.

Consultation:

Director of Technical Services

Statutory Environment:

Section 40 of the *Bush Fire Act* provides that two or more local governments may by agreement join in the appointment of bush fire control officers and that officers so appointed may exercise their power and authorities in each of the districts so appointed.

Policy Implications:

There are no policy implications.

Financial Implications:

There are no known significant financial implications.

Strategic Implications:

There are no known significant strategic implications.

Risk Implications:

Risk	
Risk Likelihood (based on history and with existing controls)	Low
Risk Impact / Consequence	Low
Risk Rating (Prior to Treatment or Control)	Low
Principal Risk Theme	Low
Risk Action Plan (Controls or Treatment Proposed)	Low

Risk Matrix

Consequence Likelihood		Insignificant	Minor	Moderate	Major	Catastrophic
		1	2	3	4	5
Almost Certain	5	Medium (5)	High (10)	High (15)	Extreme (20)	Extreme (25)
Likely	4	Low (4)	Medium (8)	High (12)	High (16)	Extreme (20)
Possible	3	Low (3)	Medium (6)	Medium (9)	High (12)	High (15)
Unlikely	2	Low (2)	Low (4)	Medium (6)	Medium (8)	High (10)
Rare	1	Low (1)	Low (2)	Low (3)	Low (4)	Medium (5)

A risk is often specified in terms of an event or circumstance and the consequences that may flow from it. An effect may be positive, negative or a deviation from the expected and may be related to the following objectives; occupational health and safety, financial, service interruption, compliance, reputation and environment. A risk matrix has been prepared and a risk rating of 1 has been determined for this item. Any items with a risk rating over 10 (considered to be high or extreme risk) will be added to the Risk Register, and any item with a risk rating over 17 will require a specific risk treatment plan to be developed.

Voting Requirements:

Simple Majority

12520 Moved: Cr Wood Seconded: Cr Freebairn

Recommendation and Council Decision:

That pursuant to Section 40 of the *Bush Fires Act*, the following Shire of Wickepin fire control officers be appointed as a dual fire control officer in the Shire of Pingelly:

- Roger Butler
- Colin Coxon
- Steve Rose

Carried 7:0

16.3 Proposed Oversized Shed

File Reference: A2468
Location: Lot 369 – 33 Raglan Street, Pingelly
Applicant: Mr T Bowron & Ms K Moulton
Author: Administration Officer Technical
Date: 28 August 2018
Disclosure of Interest: Nil
Attachments: Nil
Previous Reference: N/A

Summary:

Council to consider an application for a proposed oversized shed at Lot 369 – 33 Raglan Street, Pingelly.

Background:

Mr T Bowron & Ms K Moulton have submitted an application for planning consent for a proposed shed with an area of 84m² at Lot 369 – 33 Raglan Street.

Comment:

The proposed shed will be located at Lot 369 – 33 Raglan Street, Pingelly, which is zoned residential with an R10/R20 code and a total lot area of 2104m².

The proposed shed will be located in the north eastern corner of the property with rear access from Shannon Street, 1.5m from the eastern boundary, and 1.5m from the northern boundary and 20m from the swimming pool at the rear of the house. The proposed shed will have a total area of 84m², with a wall height of 3.3m and gable height of 4.7m. The proposed shed is oversized for outbuilding area of Lot 369 – 33 Raglan Street under *Shire of Pingelly's Policy 13.2 Outbuildings* residential zone R10 code or above. There are two existing garages on the property with a total area of 53.33m² which will give a total outbuilding area for the Lot of 137.33m².

There will be no overshadowing issues with neighbouring property as the proposed location of the shed is at the rear of Lot 369 – 33 Raglan Street with Shannon Street on the eastern boundary and the neighbouring property on northern boundary has no developments in this area that would be affected. Brown Street is on the southern boundary.

The shed will be constructed in colorbond materials.

This application to Council is required as the new shed will create a total outbuilding area over the requirements of 75m² for zoning area of R10/R20 as referenced in the Shire of Pingelly's Policy 13.2 Outbuildings.

Map Viewer

Created 20 May 2016

Scale: 1:391

Description

Map Projection: GDA 94 (Lat/Long)

Datum: Geocentric Datum of Australia 1994

1 Midland Square
Midland WA 6056
(08) 9273 7341
customer.service@landgate.wa.gov.au
www.landgate.wa.gov.au

© Western Australian Land Information Authority 2007



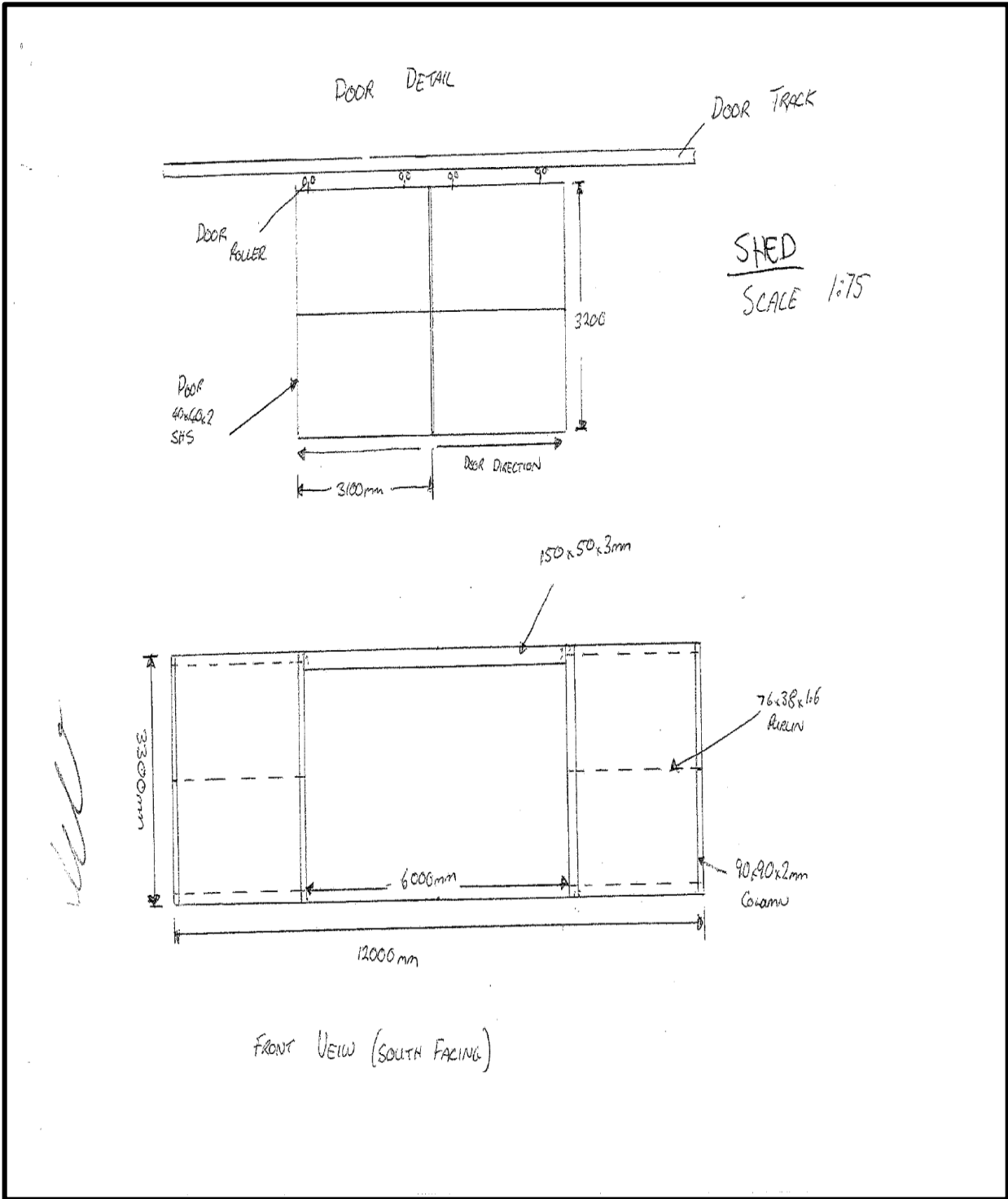

SIDE VIEW (WEST FACING WITH DOOR)
(EAST THE SAME MINUS DOOR)

3325

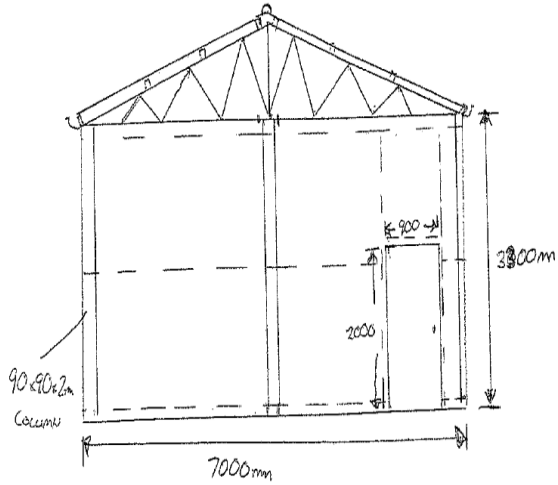

SHED
SCALE 1:75

40x60x3m FLAT
CROSS BRACING

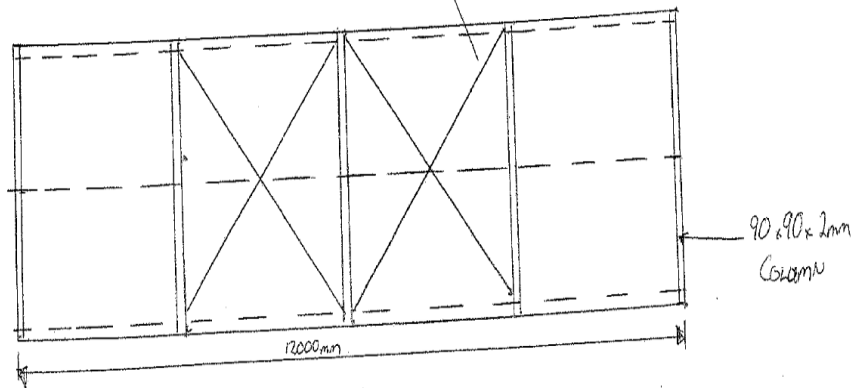

BACK VIEW (NORTH FACING)

SIDE VIEW (WEST FACING WITH DOOR)
(EAST THE SAME MINUS DOOR)

2325

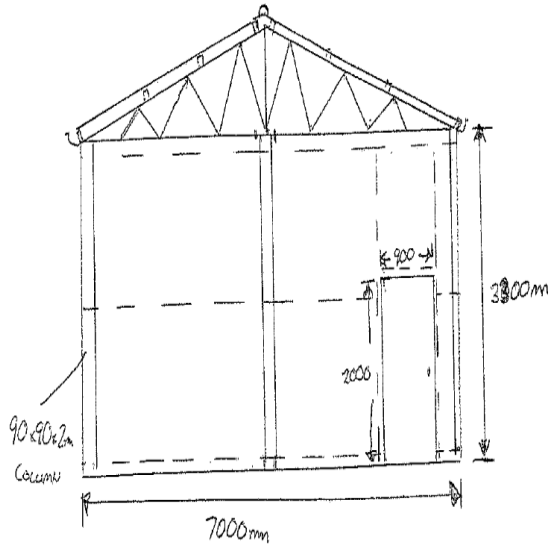

SHED
SCALE 1:75

40x60x3mm FLAT
CROSS BRACING

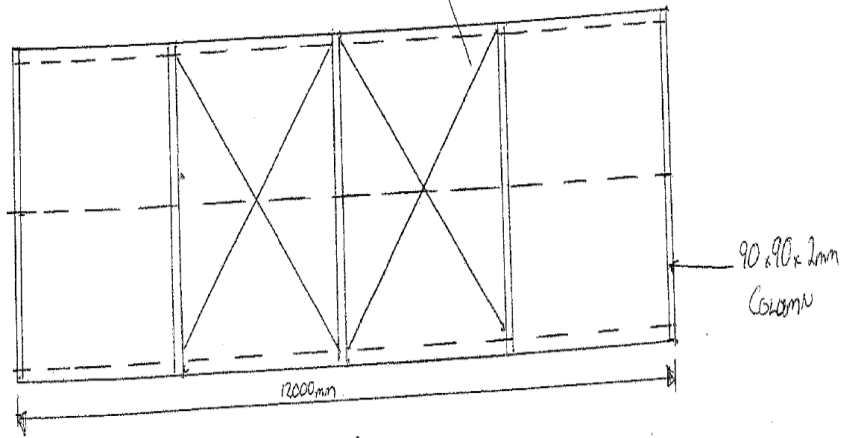

BACK VIEW (NORTH FACING)

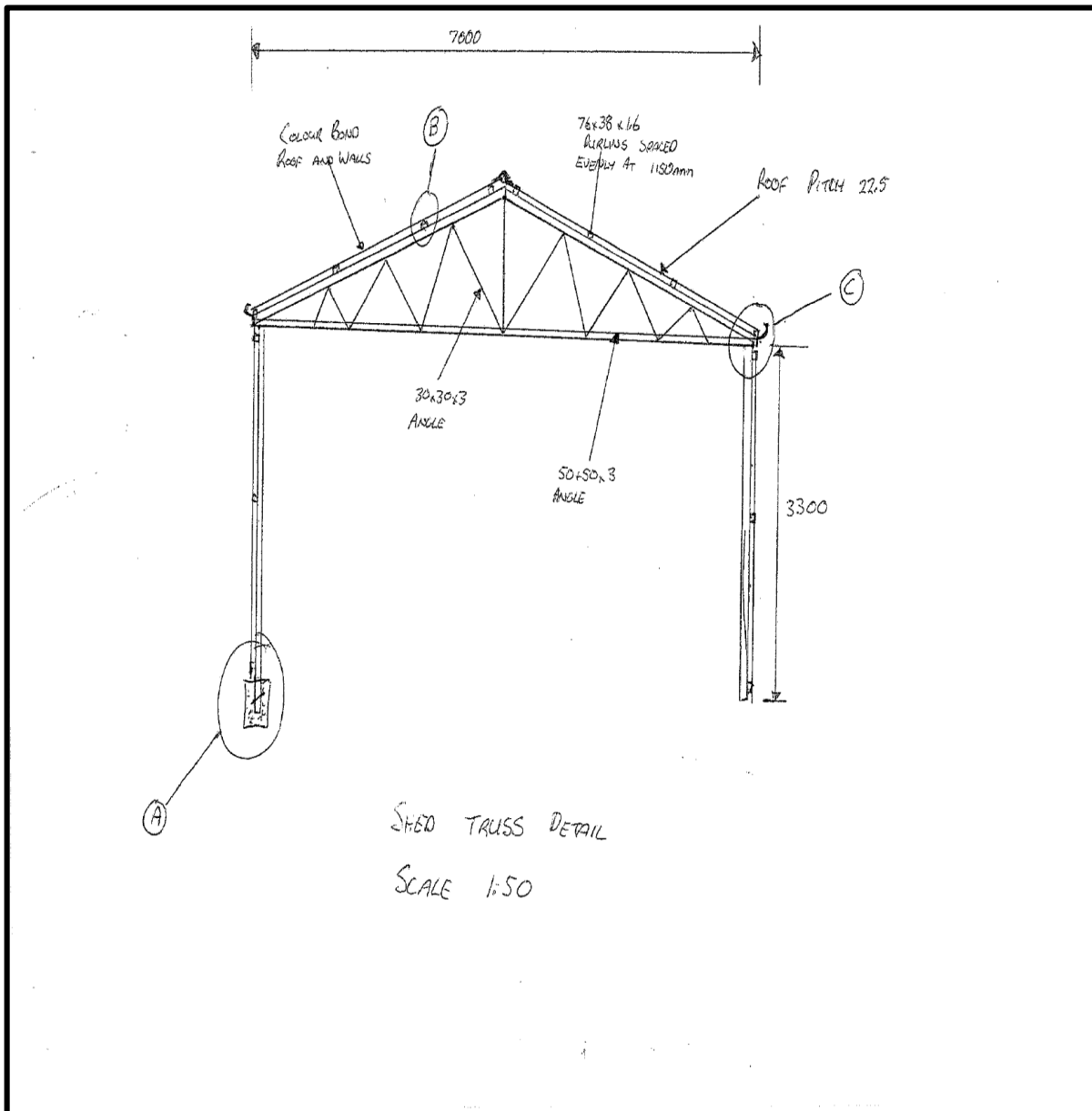

Consultation:

Barry Gibbs – Director Technical Services
Shire of Pingelly Outbuildings Policy 13.2

Statutory Environment:

Shire of Pingelly's Local Planning Scheme No.3

Policy Implications:

Shire of Pingelly's Policy 13.2 Outbuildings

Objective This policy provides direction and guidance on the area and height of outbuildings and the like that Council will permit within the Shire boundaries.

Outbuildings and structures that comply with the following requirements may be approved by Council's Building Surveyor without having the need to be submitted to an Ordinary Meeting of Council.

Policy Intention

- To provide some flexibility in the requirements for outbuildings and the like in residential areas.
- To ensure that the provisions of the current *Residential Design Codes* are appropriately addressed.
- To improve customer service standards through the timely processing of planning and building applications for outbuildings.

Policy

Definitions:

- **Outbuilding** is an enclosed non-habitable structure that is required to meet the standards of the Building Code of Australia and is detached from any dwelling.
- **Carport** is a roofed structure designed to accommodate one or more motor vehicles unenclosed except to the extent that it abuts a dwelling or a property boundary on one side and being without a door.
- **Garage** is any enclosed and roofed structure, other than a carport, designed to accommodate one or more motor vehicles.
- **Patio** is a roofed shade structure either attached to a dwelling or free standing is required to be open on fifty percent of its sides.
- **Pergola** is a light weight shade structure that does not have a solid roof. It may be attached to a dwelling or can be free standing.
- **Statutory Powers:** This policy has been prepared in conjunction with the requirements of the *Residential Design Codes of Western Australia*, i.e. The performance criteria relative to outbuildings (Clause 5.4.3) states:
“Outbuildings that do not detract from the streetscape or the visual amenity of the residents or neighbouring properties.”

Buildings are to comply with any local planning policy made under the Scheme in respect of the design of carports and garages, including the colour, scale, materials and roof pitch of buildings. This policy provides design requirements for carports and garages, however it does not interfere with any other requirement of the Residential Design Codes relating to carports and garages.

This policy does not alter or change in any way the acceptable development criteria of the *Residential Design Codes currently in force*.

Within all “Residential” and “Rural Residential” zoned areas of the Shire and on Farming zoned lots with an area of 2ha or less except as otherwise stated, planning consent for all outbuildings is required. If planning consent is granted, building approval will be issued for outbuildings which are appurtenant to a dwelling, provided all boundary setbacks and building separation requirements have been complied with, the building is of single storey construction, located behind any residence on-site and provided the proposed development complies with the following:

1. In any residential zone with an R10 code or above in the Shire:
 - a. Non-masonry construction, where the total non-masonry outbuilding area does not exceed 60m² and the total outbuilding area does not exceed 75m²;
 - b. Masonry or other approved construction, where the total outbuilding area has walls constructed of the same materials and appearance as the house and does not exceed 75m² and no parapet wall is greater in length than 8m;
 - c. Wall height of any outbuildings not to exceed 3m. This height limitation also applies to parapet walls. In the case of gable roof construction, the maximum building height is not to exceed 4.2m;
 - d. Prior to considering a parapet wall construction over 8m in length, the applicant will present Council with written agreement to the same by any affected adjoining landowner;
 - e. No planning consent or building licence approval will be granted or issued for any outbuildings, on any Residential zoned lot, which does not contain a residence;
 - f. The applicant providing the Shire with a written undertaking that the outbuilding constructed, will only be used for the purpose permitted within the zone in which it is located, under the provisions of the Shire’s operative Local Planning Scheme;
 - g. Any development application which does not comply with the above, shall be referred to Council for consideration.
2. In any residential zone with an R code below R10, the rural residential zone of the Shire and on farming zoned lots which have an area of 2ha or less
 - a. Non-masonry zincalume construction, where the total zincalume outbuilding area does not exceed 75m² and the total outbuilding area does not exceed 200m², or

- b. Non-masonry colorbond construction, where the total colorbond outbuilding area does not exceed 150m² and the total outbuilding area does not exceed 2
 - c. Masonry or other approved construction, where the total outbuilding area has walls constructed of the same materials and appearance as the house and does not exceed 200m²,
 - d. Wall height of any outbuilding not to exceed 4m. In the case of a gable roof construction, the maximum building height is not to exceed 5m;
 - e. No planning consent or building licence approval will be granted or issued, for any outbuildings on a residential or rural residential zoned lot where a building licence has not been issued for a residence and / or where an outbuilding is not located at least 4m from any boundary of the lot;
 - f. The applicant providing the Shire with a written undertaking that the outbuilding constructed, will only be used for purposes permitted within the zone in which it is located under the provisions of the Shire's operative Local Planning Scheme;
 - g. Any development application which does not comply with the above shall be referred to Council for consideration.
3. Distance from boundaries on any residential zoned lot with an R code of 10 or above:
- a. Garages, shed, pergolas and patios - brick construction
 - i. Attached to house - 1m from side boundaries. Eaves not closer than 750mm measured from the outer edge of the gutter.
 - ii. Detached from house - Must be 1.8m clear of house with either parapet wall on boundary or walls 1m from boundary with eaves 750mm clear of boundary.
 - b. Garages, sheds, pergolas, and patios - steel framed construction - Detached from house only - Must be at the rear of the residence 1.8m clear of the residence, leach drains and septic tanks and 1.2m clear of side and rear boundaries.
 - c. Carports - Columns of brick (350mm x 350mm) or steel may be erected on a boundary provided no more than 4 columns are used and roofing including guttering is at least 750mm clear of the boundary. Beams must be of steel within 750mm of a boundary and a dividing fence forming a side wall of the carport must not be higher than 1.8m. Timber framed carports must be sited 1.2m clear of boundaries.
 - d. On corner lots - Where an outbuilding is constructed in brick or clad in colorbond, Council will permit a setback of 3.75m to the minor street. Where an outbuilding is clad in zincalume a setback of 7.5m to the minor street will apply.
4. Distance from boundaries in any residential zone with an R code below R10 and the rural residential zone of the Shire and on farming zoned lots which have an area of 2 hectares or less
- a. Detached outbuildings - To be at the rear or the residence on-site, at least 1.8m clear of the residence, leach drains and septic tanks. All boundary setbacks to be as laid down in the Shire of Pingelly's operative Local Planning Scheme.
 - b. On corner lots - The setback to the minor street to be the same as the frontage setback laid down in the Shire of Pingelly's operative Local Planning Scheme.
 - c. Garden sheds - Under this policy, Council will without the need for planning consent or building permit approval, permit the erection of one only garden shed per lot which has a maximum area of up to 10m². The garden shed is to be located on the lot in a position and in a manner agreed to in writing by the Shire's Building Surveyor and such shed is in addition to any other shed permitted under this "Policy".

Financial Implications:

Nil

Strategic Implications:

Nil

Risk Implications:

Risk	
Risk Likelihood (based on history and with existing controls)	Low
Risk Impact / Consequence	Low
Risk Rating (Prior to Treatment or Control)	Low
Principal Risk Theme	Low
Risk Action Plan (Controls or Treatment Proposed)	Low

Risk Matrix

Consequence Likelihood		Insignificant 1	Minor 2	Moderate 3	Major 4	Catastrophic 5
Almost Certain	5	Medium (5)	High (10)	High (15)	Extreme (20)	Extreme (25)
Likely	4	Low (4)	Medium (8)	High (12)	High (16)	Extreme (20)
Possible	3	Low (3)	Medium (6)	Medium (9)	High (12)	High (15)
Unlikely	2	Low (2)	Low (4)	Medium (6)	Medium (8)	High (10)
Rare	1	Low (1)	Low (2)	Low (3)	Low (4)	Medium (5)

A risk is often specified in terms of an event or circumstance and the consequences that may flow from it. An effect may be positive, negative or a deviation from the expected and may be related to the following objectives; occupational health and safety, financial, service interruption, compliance, reputation and environment. A risk matrix has been prepared and a risk rating of 1 has been determined for this item. Any items with a risk rating over 10 (considered to be high or extreme risk) will be added to the Risk Register, and any item with a risk rating over 17 will require a specific risk treatment plan to be developed.

Voting Requirements:

Simple Majority

12521 Moved: Cr Hodges Seconded: Cr Hastings

Recommendation and Council Decision:

Council to grant planning approval for the erection of the proposed oversized shed at Lot 369 – 33 Raglan Street, Pingelly which is to be used ancillary to the dwelling and not for commercial purposes.

Carried 6:1

16.4 Secondary Freight Route Project

File Reference:	ADM0093
Location:	Various Roads – Wheatbelt North and South
Applicant:	Wheatbelt Regional Road Group North and South
Author:	Director Technical Services
Date:	5 September 2018
Disclosure of Interest:	The author has no interest in this matter
Attachments:	Wheatbelt Secondary Freight Route Briefing Note (Attachment 6 following yellow sheet in separate attachments booklet)
Previous Reference:	RRG – Hotham Dale Sub Group briefing to Council since June 2016

Summary:

Council to consider this proposal relating to progression of the Wheatbelt Secondary Freight Routes Project that involves preparation of grant application under the Commonwealth Government 'Building Better Regions Fund' (BBRF).

In order to prepare the grant application the respective Regional Road Groups for the Wheatbelt North and South are seeking continued cooperation and commitment from all member Local Governments to endorse the strategic intent, and contribute co-funding to the feasibility and condition assessment of the project should the BBRF funding application be approved.

Background:

Description of Proposal:

The Wheatbelt Secondary Freight Routes Project seeks to establish a common Restricted Access Vehicle (RAV) road standard across municipal boundaries to aid in the safe and efficient movement of freight.

At this stage, 42 Local Governments within the Wheatbelt are being requested to continue their support and commitment to the project, with the focus on preparing and lodging a BBRF funding application for an amount of \$3,500,000 for the preparation of a robust business case to support the project.

Through various Regional Road Group forums and Sub-Group meetings the idea of a Secondary Road Network was formed to move freight effectively and efficiently from farming properties to main arterial roads. It was quickly identified that this required a consistent RAV standard of road classification to be applied across municipal boundaries within the Wheatbelt region.

This resulted in the Wheatbelt Secondary Freight Routes Project being spawned. A briefing note broadly detailing the nature of this project, the works completed and the methodology to be applied moving forward is provided as an attachment.

A email from the Chair of the Wheatbelt South Regional Road Group, Cr Crute, is reproduced below. This email provides explanation on approach taken and need for continued 'buy in' from all member Local Governments within the Wheatbelt.

Good morning Everyone,

At the most recent meeting of the WBS RRG the delegates asked me to write to you all requesting that all Council's reaffirm their commitment to the Wheatbelt Secondary Freight Project and commit \$6000 in their 19/20 budgets as the co-contribution required from all 42 LG's for the funding application we will be submitting over the coming months to undertake the detailed planning and design works to enable us to have a Level 4 Infrastructure Australia Submission prepared.

We acknowledge that a lot of councillors will not be intimately aware of the project, so to that end Garrick Yandle together with the Working Group have prepared a detailed Briefing document that we would like you to include with the agenda item for your councillors.

We are requesting that all LG's present the motion as is below, our intent is to have 42 LG's adopted the exact same position, so that we continue to present a united front. It is this collaboration and agreement that is getting us significant traction both at a Federal and State Government Level. We would like you to present this recommendation and supporting documentation to your councils in the

August round of Council meetings, following these meetings we would like you to write back to me as Chair of WBS RRG confirming the motion that was passed by council.

For those that aren't away the WSFR Project has been working on this project since mid 2016; the project stemmed from considerable work done by both WBS & WBN in looking at their road networks in attempt to improve connectivity through our RRG funding and road projects. This mapping process started in 2014, once the RRG together with Main Roads identified that improving the connectivity was a major project that would bring significant economic benefit to the Ag Region a working group was formed and RDA via Juliet Grist helped us obtain initial funding to further progress this as a regional road project. The last 2 ½ years have seen considerable work undertaken by all 42 LG's and the working group to get this project to a point where we are starting to have constructive and positive meetings with the State Government, Federal Government, Infrastructure Australia, Freight & Logistics Council WA, CBH and other key stakeholders.

Hopefully this provides your councils with sufficient information about the background of the project and the plan going forward to enable them to provide the working group with formal support, so we can continue to work for what is a significant regional project for Wheatbelt Region.

Kind regards,

Katrina Crute

Chair of the Wheatbelt South Regional Road Group

Comment:

The Council has demonstrated a commitment to this project at previous corporate discussions over the past 2 years. Overall as a concept, the project has generated a level of confidence in preparing a funding application that could receive favourable consideration at the Federal Government level. However, this is conditional on a financial contribution being pledged by the Local Government sector, which has given rise to this request and report being prepared.

Consultation:

This project to date has been widely discussed and promoted at:

- Various Wheatbelt Regional Road Group and Sub-Group meetings;
- Western Australian Local Government Association Country Zone meetings;
- Council Briefing Forums;
- Other State Government meetings
- Commonwealth Government Agency meetings.

Statutory Environment:

At this stage there is no statutory requirements applicable to this matter.

Policy Implications:

There are no known policy implications.

Financial Implications:

Commitment is sought from member Local Governments for a contribution of \$6,000 toward preparation of a business case, including cost benefit analysis for the Secondary Freight Routes Project. An allocation for this amount will need to be included in the 2018/19 mid-year budget review.

Strategic Implications:

This proposal relates to delivery of core business and services detailed in the Shire of Pingelly.

Outcome 2.6: Safe and reliable transport infrastructure

Strategy 2.6.1: Maintain and further develop roads and footpaths at appropriate standards within financial constraints

Strategy 2.6.2: Explore alternative heavy haulage routes and funding options

Strategy 2.6.3: Investigate and respond to transport infrastructure safety issues

Risk Implications:

Risk	
Risk Likelihood (based on history and with existing controls)	Low (4)
Risk Impact / Consequence	Low (4)
Risk Rating (Prior to Treatment or Control)	Low (4)
Principal Risk Theme	Low (4)
Risk Action Plan (Controls or Treatment Proposed)	Low (4)

Risk Matrix

Consequence Likelihood		Insignificant 1	Minor 2	Moderate 3	Major 4	Catastrophic 5
Almost Certain	5	Medium (5)	High (10)	High (15)	Extreme (20)	Extreme (25)
Likely	4	Low (4)	Medium (8)	High (12)	High (16)	Extreme (20)
Possible	3	Low (3)	Medium (6)	Medium (9)	High (12)	High (15)
Unlikely	2	Low (2)	Low (4)	Medium (6)	Medium (8)	High (10)
Rare	1	Low (1)	Low (2)	Low (3)	Low (4)	Medium (5)

A risk is often specified in terms of an event or circumstance and the consequences that may flow from it. An effect may be positive, negative or a deviation from the expected and may be related to the following objectives; occupational health and safety, financial, service interruption, compliance, reputation and environment. A risk matrix has been prepared and a risk rating of 1 has been determined for this item. Any items with a risk rating over 10 (considered to be high or extreme risk) will be added to the Risk Register, and any item with a risk rating over 17 will require a specific risk treatment plan to be developed.

Voting Requirements:

Simple Majority

12522 Moved: Cr Hodges Seconded: Cr Wood

Recommendation:

- 1. Acknowledges the Secondary Freight Routes Project Briefing Note, presented as an attachment to this report.**
- 2. Supports the strategic intent of the Secondary Freight Routes Project;**
- 3. Authorises the Chief Executive Office to prepare and sign a letter of support in favour of an application for Federal Government Funding under the Building Better Regions Program to develop the Wheatbelt Secondary Freight Routes Project; and**
- 4. Endorses an allocation of \$6,000 to be included in the 2018/19 Shire of Pingelly mid-year budget review to co-fund the Secondary Freight Route Project development, subject to a successful Building Better Regions Program application.**

12523 Moved: Cr Walton-Hassell Seconded: Cr Wood
to change Item 4 - 18/19 to 19/20 financial year.
Delete the wording “mid year review” in item 4.

Carried 4:3

**12524 Moved: Cr Walton-Hassell Seconded Cr Wood
Council Decision:**

- 1. Acknowledges the Secondary Freight Routes Project Briefing Note, presented as an attachment to this report.**
- 2. Supports the strategic intent of the Secondary Freight Routes Project;**
- 3. Authorises the Chief Executive Office to prepare and sign a letter of support in favour of an application for Federal Government Funding under the Building Better Regions Program to develop the Wheatbelt Secondary Freight Routes Project; and**
- 4. Endorses an allocation of \$6,000 to be included in the 2019/20 Shire of Pingelly budget to co-fund the Secondary Freight Route Project development, subject to a successful Building Better Regions Program application.**

Carried 6:1

12525 Moved: Cr Hastings Seconded: Cr Hotham

Council Decision:

That as per section 5.23(2) of the *Local Government Act 1995* the meeting be closed to members of the public to allow Council to discuss a confidential item.

Carried 7:0

Craig McLennan, Elly Bond and Ann Murray left the meeting at 2.52pm and did not return. Barry Gibbs left the room at 2.52pm and returned at 2.54pm.

16.5 Confidential Item – Land Use Lots 168 and 169 Taylor Street Pingelly

File Reference: ADM0101/A5396
Location: Lots 168 and 169 Taylor Street Pingelly
Applicant: Shire of Pingelly
Author: Director Technical Services
Date: 7 September 2018
Disclosure of Interest: The author has no interest in this matter
Attachments: Letter from Main Roads WA Dated 22 August 2018, Quote from Ecoedge.
Previous Reference: Confidential Item 14.4 Land Usage of Lot 168 and 169 Taylor Street Pingelly from the Ordinary Meeting of Council held on 18 July 2018

Barry Gibbs, Stuart Billingham and David Freebairn left the meeting at 3pm and returned at 3.01pm.

12526 Moved: Cr Hotham Seconded: Cr Walton-Hassell

Council Decision:

That Council work with Pingelly Transport to enter into a Memorandum of Understanding for relocation to a suitable property within the Shire's Light Industrial Area.

Carried 7:0

17. ELECTED MEMBERS MOTIONS OF WHICH PREVIOUS NOTICE HAS BEEN GIVEN

17.1 Confidential Item – Presented Correspondence

Barry Gibbs, Stuart Billingham and Lisa Boddy left the room at 3.26pm and returned at 4pm.

12528 Moved: Cr Walton- Hassell Seconded Cr Hodges

Council Decision:

To adjourn the meeting for a short break at 4.15pm.

Carried 7:0

12529 Moved Cr Walton-Hassell Seconded: Cr Wood

Council Decision:

To recommence the meeting at 4.36pm

Carried 7:0

12531 Moved: Cr Hastings Seconded: Cr Hotham

Council Decision:

That Council authorises the Shire President to discuss with the Chief Executive Officer the contents of the correspondence presented.

Carried 7:0

12530 Moved Cr Walton-Hassell Seconded: Cr Wood

To re-open the meeting to the public. All that were in attendance before the break returned to the meeting.

Carried 7:0

12527 Moved: Cr Hotham Seconded: Cr Walton-Hassell

Council Decision:

That Council work with Pingelly Transport to enter into a Memorandum of Understanding for relocation to a suitable property within the Shire’s Light Industrial Area.

Carried 7:0

12532 Moved: Cr Hastings Seconded: Cr Hotham

Council Decision:

That Council authorises the Shire President to discuss with the Chief Executive Officer the contents of the correspondence presented.

Carried 7:0

18. NEW BUSINESS OR URGENT BUSINESS INTRODUCED BY DECISION OF THE MEETING

New business of an urgent nature introduced by decision of the meeting. Best practice provides that Council should only consider items that have been included on the Agenda (to allow ample time for Councillors to research prior to the meeting) and which have an Officer Report (to provide the background to the issue and a recommended decision).

Nil.

19. CLOSURE OF MEETING

The Chairman declared the meeting closed at 4.37pm.

These minutes were confirmed by Council at the Ordinary Council Meeting held on 17 October 2018.

Signed.....
Presiding Person at the meeting at which the minutes were confirmed.